



Instruction Manual
ExTox Control Units
Series ET-8 and ET-4D2

Foreword

We thank you very much for your confidence in our products and us, the ExTox Gasmess-Systeme GmbH.

The Control Units of the Series ET-8D and ET-4D2 as well as all other ExTox-Products and services stand for our high quality targets. Our business is the health protection of mankind, protection of the environment and installations. We are glad to take this responsibility. Our Quality Management System therefore follows ISO 9001 and our Production Monitoring is to keep the European Directives 94/9/EC („ATEX“). You profit of the high reliability due to modern sensor techniques and consequent interpretation acc. to the requirements of the regulations and standards valid for industrial application.

The Control Units of the Series ET-8D and ET-4D2 are a compact and easily understandable system for up to four or eight transmitters which covers also complex monitoring tasks. By means of their interfaces they are easy to integrate even in higher control and management systems. They could be used in combination with all ExTox Transmitters ExSens (-I) and Sens (-I).

Please do not hesitate to contact anytime in case of questions or if you require information:

ExTox Gasmess-Systeme GmbH
Max-Planck-Straße 15 a
59423 Unna
Germany
Telefon: +49(0)2303 33 247 0
Fax: +49(0)2303 33 247 10
E-mail: kontakt@ExTox.de
Internet: www.ExTox.de

BA_ET-8D_ET-4D2_e_2014-01-31.doc, Rev.: 31.01.2014
Software Version ET-8D: ET881118 [CE Ⓜ II (2)G] otherwise [CE Ⓜ II (3)G]
Software Version ET-4D2: ET481118 [CE Ⓜ II (2)G] otherwise [CE Ⓜ II (3)G]
(Subject to Technical Changes)

Content

1	Introduction	6
2	Features of The Control Units	7
2.1	Series ET-8D	7
2.2	Series ET-4D2	8
2.3	Common Features of the Series ET-8D and ET-4D2	8
3	Indications and Facilities of the Control Units	9
3.1	Series ET-8D	9
3.2	Series ET-4D2	10
4	Configuration	12
4.1	Channel Configuration	13
4.2	Relay Configuration	15
4.3	Calibration	16
4.4	Time/Date	17
4.5	Analogue Inputs	17
4.5.1	Series ET-8D	17
4.5.2	Series ET-4D2	18
4.6	Adjustment	18
4.7	Password	19
4.8	System Parameters	20
4.8.1	Maintenance	20
4.8.2	Inputs 4...20 mA	21
4.8.3	Memory Test	22
4.8.3.1	Series ET-8D	22
4.8.3.2	Series ET-4D2	23
4.8.4	Language	23
4.8.5	Mode	23
4.8.6	Options	24
4.8.7	AQUIT	24
4.8.8	Alarm	24
5	Operation of the Control Unit	25
5.1	Measuring Mode	25
5.2	Deactivation of Channel	25
5.3	Alarms	26
5.4	Under-Scale and Over-Scale of Measuring Range	26
5.5	Channel Fault	27
5.6	Fault of Control Unit	28
5.7	Programme Run Monitoring (Watchdog)	28
5.8	Initialisation (Start-up of System)	28
5.9	Analogue Outputs 4...20 mA (only Types ET-8DA and ET-4DA2)	29
5.10	Digital Inputs	29
5.11	Smoke Detectors	29
5.11.1	Series ET-8D	29
5.11.2	Series ET-4D2	29
5.12	RS 485-Interfaces for Transmitter ExSens-I and Sens-I	29

6	Digital Data Output	30
6.1	Data Formate	30
6.2	Parameters of Serial Data Transfer	30
6.3	Composition of recorded Data	31
6.3.1	Series ET-8D	31
6.3.2	Series ET-4D2	33
6.4	Interface Profibus DP [®] or ModBus [®]	33
7	Application	34
7.1	Measuring Function	34
7.2	Use in combination with hazardous Areas	34
8	Installation	35
8.1	Mechanical Installation	35
8.2	Electrical Installation	35
8.3	Smoke Detectors	36
8.3.1	Series ET-8D	36
8.3.2	Series ET-4D2	36
9	Maintenance of Gas Detection Systems	38
9.1	Basic Information	38
9.2	Visual Check	38
9.3	Functional Check	38
9.4	System Check	39
10	Options	39
11	Technical Data and Declaration of Conformity	39

1 Introduction

This Instruction Manual generally describes operation, installation and maintenance of the following ExTox-Products:

Article-No.	Wall Mounted Housing		DIN-Rail		Control Panel		19"-Rack	
	230 V	24VDC	230 V	24VDC	230 V	24 VDC	230 V	24 VDC
ET-8D	320000 ¹	320003	320006	320007	320001	320004	320002, + Rack 320008	320005, + Rack 320009
ET-8DA	322000	322003	322006	322007	322001	322004	322002, + Rack 322008	322005, + Rack 322009

Article-No.	Wall Mounted Housing		DIN-Rail		Control Panel		19"-Rack	
	230 V	24VDC	230 V	24VDC	230 V	24 VDC	230 V	24 VDC
ET-4D2	315000 ¹	315004 ¹	315001	315005	315002	315006	315002, + Rack 315008	315007, + Rack 315009
ET-4DA2	317000	317004	317001	317005	317002	317006	317002, + Rack 317008	317007, + Rack 317009

Type specific data for each device should be taken from a corresponding separate and specific Data Sheet. This Data Sheet forms consequently part of this Instruction Manual. References on the Data Sheet within this text are marked with \varnothing DB.

Please read this Instruction Manual carefully before installation and initial operation of the control unit. We kindly ask you to pay attention to all details and cross-references.

Single types of Control Units can be supplied with EC-Type Test of Measuring Function for Explosion Protection acc. to EC-Directive 94/9/EG (ATEX) on demand (\varnothing DB). These types are always supplied with Software Versions ET881118 (ET-8D) and ET481118 (ET-4D2). These Control Units show the special marking $\text{CE} \varnothing$ II (2)G on the type label.

Deviations of the EC-Type Test-Software Version in comparison to the current Software Versions are described in grey writing within this Instruction Manual.

We kindly ask you not to repair the control unit or to perform any changes which go beyond the measures described herein. Otherwise you endanger your own safety and your warranty claims of merchantability. In such cases please contact ExTox or authorised ExTox Service Partner. Third parties take the responsibility for correct performance of work if maintenance and repairs are done by them.

On receipt of goods please take care that packing and consignment are not damaged and the goods supplied correspond to the articles described in the delivery note. Please do also compare with your order. In case of any damage please inform your forwarding agent and your supplier. Please keep the damaged packing.

Please keep in mind that control units are sensitive measuring devices and take special care when unpacking and installing them

¹ Also available with integrated ProfiBus® DP-module (Art. 825009):
ET-8DP, 230 V (Art. 320010), ET-8DP, 24 V (Art. 320011), ET-4DP2, 24 V (Art. 315010)

2 Features of The Control Units

Concentrations of flammable and toxic gases as well as of oxygen are centrally evaluated by the Control Units of the Series ET-8D and ET-4D2 after measuring them safely with our Ex-Tox transmitters.

The Control Units could be combined with all ExTox-Transmitters ExSens (-I) and Sens (-I). The control units are available in wall mounted housing, for DIN-Rail installation and for installation in 19"-Rack or Control Panel. The power supply can flexibly be done with 230 V (85...264 V AC, 120...340 V DC) or 24 V DC. On request we could supply you with corresponding uninterruptible power supplies for our control units.

The control units in combination with ExTox transmitters comply with EN 60079-29-1 and EN 45544 for Gas Detection Systems. Furthermore they are in conformity with the European Directives 94/9/EC (ATEX), 2004/108/EEC (EMC) and 2006/95/EEC (LVD).

2.1 Series ET-8D



- 8 input channels for transmitter (4-20 mA, three-wire system) or smoke detector
- 24 relay outputs, potential free, freely configurable
- Illuminated graphic display (240 x 64) for indication of measured values, messages and alarms
- 8 analogue outputs, potential free (only Type ET-8DA)
- Measuring function for explosion protection: in conformity with Directive 94/9/EC (ATEX)
 - Wall mounted housing, 230 V AC, Software ET881118, Operation ET-8:
CE II (2)G
 - otherwise: CE II (3)G

2.2 Series ET-4D2



- 4 input channels for transmitter (4-20 mA, three-wire system) or smoke detector
- 12 relay outputs, potential free, freely configurable
- 4 analogue outputs, potential free (only Type ET-4DA2)
- Measuring function for explosion protection: in conformity with Directive 94/9/EC (ATEX)
 - Wall mounted housing, 230 V AC, Software ET481118, Operation ET-4:
 - $\text{CE} \text{ II (2)G}$
 - otherwise: $\text{CE} \text{ II (3)G}$

2.3 Common Features of the Series ET-8D and ET-4D2

- 4 digital inputs, potential free
- 3 freely adjustable alarm levels per channel (ascending, descending or window range), latching configurable
- 1 fault indication per transmitter
- 2 relay outputs, potential free, for indication of device fault and activated service mode
- LEDs for alarms, operation, channel fault, device fault and service mode
- service mode, horn reset and re-triggering of alarms
- RS 232- and RS 485-Interface for communication with PC or PLT-System
- Profibus DP-Interface (as option), additional interfaces on request
- Data transfer of all measured values and status messages via interfaces
- Menu controlled configuration without further tools needed

3 Indications and Facilities of the Control Units

3.1 Series ET-8D

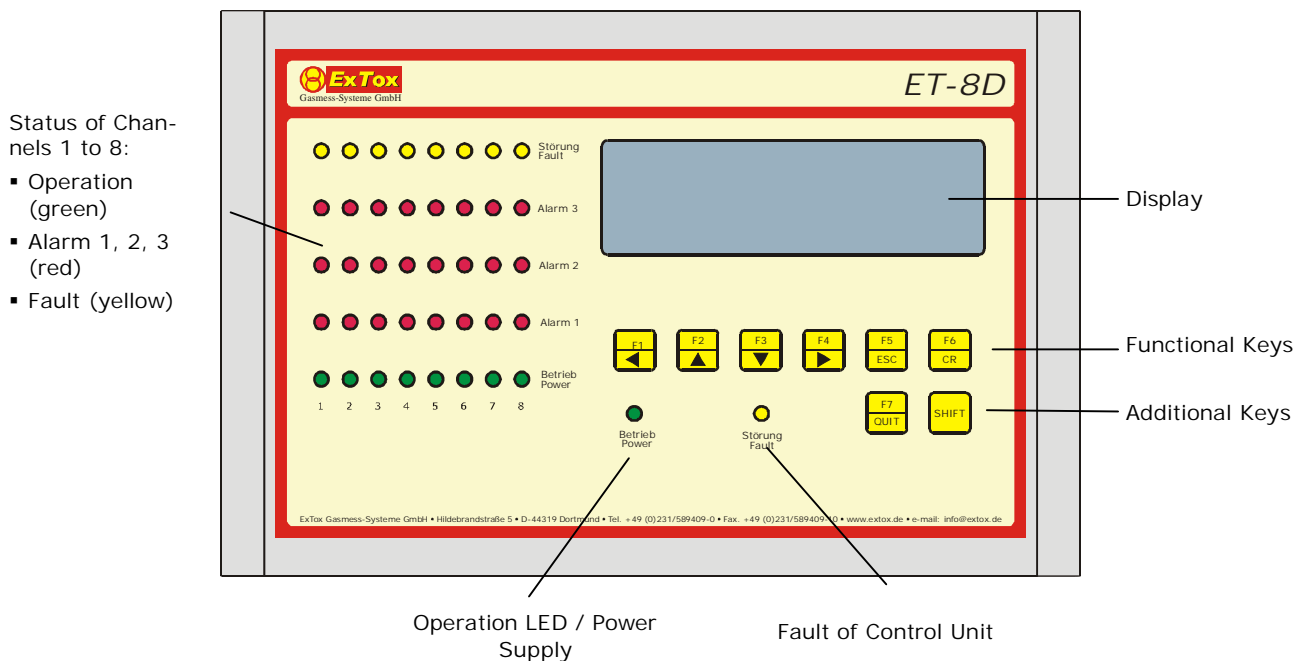

The display indication and the assignment of the functional keys F1 to F6 varies in the different operation modes of the ET-8D. The corresponding assignment of the functional keys is indicated in the line at the bottom of the graphic display.

The functional keys dispose of a repeating function that means on longer operation the selection list is quickly leafed through.

Under normal operation (Chapter 5) the display shows one of two standard settings. By pressing the functional keys SHIFT and F6 simultaneously you could every time switch between these two settings.

1. *Bar graph and detail indication:* the display gives on the left side a survey on the actual measured values of all channels in the form of a bar graph diagram. The indicated values range from 0 to 100 % end of measuring range. The adjusted alarm levels are additionally indicated as dash at the border of the bars in case the transmitter is in operation. On the right side of the display actual data of status for a selected transmitter as well as date and time are indicated. In the bar graph the corresponding channel is marked by an arrow. The data of status consist of: number of channel, type of gas, actual measured value including unit, operation status, alarm status and fault status. By means of the functional keys F1 (<CH) and F2 (CH>) it can be switched between the channels.
2. *Survey on measured values:* the actual values of all eight channels are indicated as numerical value including corresponding physical unit.

The menu for configuration of parameters (Chapter 4) is reached by pressing F6 (Setup). There a menu item can be selected by using F1 (<) and F4 (>). By using F2 (^) or F3 (v) the parameter settings can be changed. By pressing F5 (ESC) a menu can be left without any changes in comparison with the latest stored version. F6 is to select a sub-menu or to save the set parameters. Any deviation from these rules being generally valid will be separately indicated in the following descriptions.

If an alarm is configured as latching, it has to be reset manually in case the alarm condition is no longer present.

For that purpose the *bar graph and detail indication* setting has to be activated in the display. Then you have to select the corresponding channel and afterwards the Alarm A1, A2, A3 via the functional keys F3 (<AL) or F4 (AL>). The alarm can be deleted by pressing functional key F5 (AQUIT). In case of a fault perform the equivalent procedure.

If relays had been configured as reset able (see chapters 4.2), they can be reset by pressing the button F7 (Quit). The *bar graph and detail indication* setting has to be activated. This function shall be used for acoustic alarms (horn, buzzer) only.

3.2 Series ET-4D2

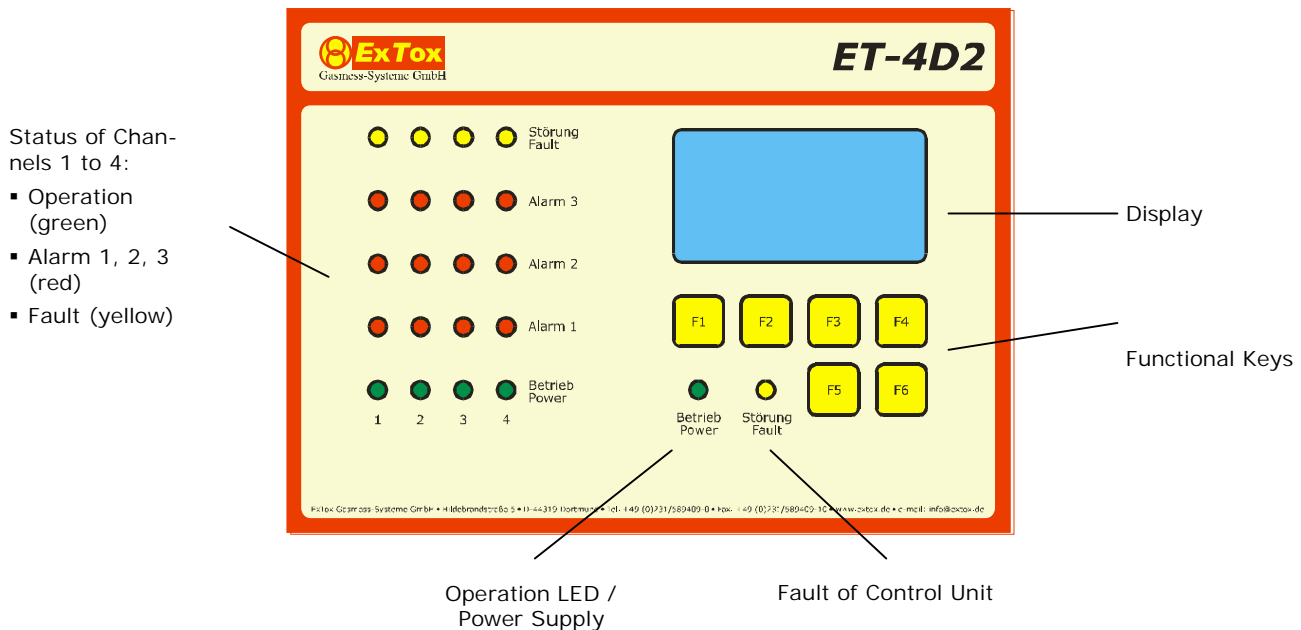

The display indication and the assignment of the functional keys F1 to F6 varies in the different operation modes of the ET-4D2. The corresponding assignment of the functional keys is indicated in the two lines at the bottom of the graphic display.

The functional keys dispose of a repeating function that means on longer operation the selection list is quickly leafed through.

Under normal operation (Chapter 5) the display shows one of two standard settings. By pressing the functional keys F4 and F6 simultaneously you could every time switch between these two settings.

3. *Bar graph and detail indication*: the display gives on the left side a survey on the actual measured values of all channels in the form of a bar graph diagram. The indicated values range from 0 to 100 % of measuring range. The adjusted alarm levels are additionally indicated as dash at the border of the bars in case the transmitter is in operation. On the right side of the display actual data of status for a selected transmitter as well as date and time are indicated. In the bar graph the corresponding channel is marked by an arrow. The data of status consist of: number of channel, type of gas, actual measured value including unit, operation status, alarm status and fault status. By means of the functional keys F1 (<CH>) it can be switched between the channels.

4. *Survey on measured values*: the actual values of all four channels are indicated as numerical value including corresponding physical unit.

The menu for configuration of parameters (Chapter 4) is reached by pressing F4 (SETUP). There a menu item can be selected by using F1 (<) and F4 (>). By using F2 (^) or F3 (v) the parameter settings can be changed. By pressing F5 (ESC) a menu can be left without any changes in comparison with the latest stored version. F6 (SELECT/SAVE) is to select a

sub-menu or to save the set parameters. Any deviation from these rules being generally valid will be separately indicated in the following descriptions

If the alarm is configured as latching, it has to be reset manually in case the alarm condition is no longer present.

For that purpose the *bar graph and detail indication* has to be activated. Now the corresponding channel has to be selected on the display by means of the functional key F1 (<CH>) and then Alarm A1, A2, A3 by means of the functional key F2 (<AL>). The alarm can now be deleted by means of the functional key F3 (AQUIT). In case of a fault perform the equivalent procedure.

If relays had been configured as reset able (see chapters 4.2), they can be quit by pressing the functional key F5. To use this function you have to choose the *Bar graph and detail indication*. This function shall be used for acoustic alarms (horn, buzzer) only.

4 Configuration

The description of configuration possibilities follows the menu structure of the ET-8D and ET-4D2. The structure is the same for both control units.

The following information is given for each parameter:

- Menu text: denomination in the menu on the display (Due to the different resolution of the displays the text of ET-8D and ET-4D2 could slightly differ from each other. Abbreviations or specialities are indicated in brackets.)
- Selection: setting of the parameters
- Function: description of the impacts on the condition of the control unit.

The control units dispose of three password protected Access Levels which are protected by four figure combinations ("password"). You will find the description of how to enter the protected Access Levels in Chapter 4.7. In case there is no selection or setting done at the control units for 10 minutes the Access Level is automatically locked again.

The passwords for all three levels are recorded on the test certificate which is added to the documentation of your control unit. Please make sure that the passwords are only handed over to the allowed persons.

Attention: On Access Level 3 very important basic settings for the safe function of the gas detection device could be changed. This level should only be accessible for especially trained staff. Therefore this level is reserved for the ExTox-Service.

Level	Rights	Access via Menu
none	<ul style="list-style-type: none"> ▪ Indication of all parameter settings, memory tests, system voltage, analogue inputs ▪ Quitting of alarms ▪ Reset of relays ▪ Change of language for indication on display 	-
1	+ <ul style="list-style-type: none"> ▪ Setting of Date and Time ▪ Activate service mode 	Password (4.7)
2	+ <ul style="list-style-type: none"> ▪ Configuration of channels ▪ Configuration of relays 	Password (4.7)
3	+ <ul style="list-style-type: none"> ▪ Adjustment of channels ▪ Setting of system parameters ▪ Change of device mode (<i>Attention:</i> only be done by Ex-Tox.) 	Password (4.7)

If not otherwise indicated the evaluation of measured values, alarms and faults during configuration is done like in normal operation.

4.1 Channel Configuration

Access Level to perform changes of the parameter settings: 2

Attention: For transmitters based on the measuring principle catalytic combustion and semi-conductor the sensor signal might fall again into the measuring range due to the suppression of oxygen at very high concentrations of flammable gases. To recognize safely that the end value of measuring range has been exceeded the latching for channel fault has to be selected for these transmitter types. Furthermore the standard setting has to be chosen for Parameter *FA*. For correct behaviour in case of alarm see 5.4.

Menu Text	Selection	Function
Setup Channel	1 to 8 (4)	Selection of channel to be adjusted. <i>Attention:</i> During channel configuration the status of alarm and fault messages remains frozen for the selected channel that means there is no monitoring for this channel. The interruption of the normal measuring operation is indicated by a blinking status LED Operation for this channel. Already stored changes will only be activated if another channel is selected or the menu is left.
Gas	List	The chemical totals formula belonging to the measured gas could be selected. It is indicated on the display during measuring operation. We recommend to select "---" on top of the list as gas type for deactivated channels. When measuring temperature please choose "TEMP", "pH" for pH-Measurement and "RM" for smoke detectors.
Dimension (DIM)	% LEL, % (v/v), ppm, pH, DEG	Unit for the measuring range. It is displayed on indication of the measured value during measuring operation.
Decimal Point (DP)	0, 0.0	It is fixed whether the measured value is displayed with decimal point. <i>Attention:</i> The change of this parameter affects also the settings of end value of measuring range and alarm levels.
Range (Messber., MB)	0.1 to 5000.0, 1 to 50000	Fixes the end value of measuring range. <i>Attention:</i> Please pay attention to the correct selection of the measuring range. In order to allow flexible adjustment even for special measuring tasks we did not integrate any plausibility control, such for example limitation to 100 for dimensions % LEL.

Menu Text	Selection	Function
Alarm Levels AL1, AL2, AL3 (left column)	0 to end value of measuring range (MBE)	<p>Fixes the three alarm levels and the direction of exceeding for triggering of alarms.</p> <ol style="list-style-type: none"> Values of alarm levels are in <i>ascending</i> order ($0 \leq AI1 < AI2 < AI3 \leq MBE$): alarms are triggered on <i>exceeding</i>. Values of alarm levels are in <i>descending</i> order ($MBE \geq AI1 > AI2 > AI3 \geq 0$): alarms are triggered on <i>under-run</i>. Alarm level 3 = 0 and Alarm level 1 < Alarm level 2 ($AI3 = 0$ and $AI1 < AI2$): Alarm 1 is triggered on under-run, Alarm 2 is triggered on exceeding (window range) <i>Example Methane concentration in biogas:</i> Alarm 1: 40 % (v/v) CH₄, Alarm 2: 60 % (v/v) CH₄. Alarming is done in case the range of 40 to 60 % (v/v) is left downwards or upwards. <p>Please note that all alarm levels have to differ at least for a minimum. In case the Alarm level 3 is not necessary it should be configured in case a. to the end value of measuring range and in case b to 0. There is no evaluation of alarms if they are adjusted on 0.</p> <p>All other constellations of parameters are rejected by the Software when trying to store them.</p> <p>If you use the Adjustment Function (see 4.6) of the control unit please pay attention to the remarks for selection of alarm levels described therein.</p>
Mode (M, left column)	On, Off	Switches on or off the evaluation of channel. The status is indicated by means of the status LED operation during measuring operation. (On = green LED on, Off = green LED off)
FA	0, 1	<p>Indicates whether the alarm evaluation should be activated (1) or whether the alarms should be locked and reset (0) in case of channel alarm.</p> <p>Standard setting: 1</p> <p><i>Attention:</i> deviations from the standard settings should not be performed for most of the safety concepts. Any deviation should be assured by superior safety concepts.</p>
Latching AL1, AL2, AL3 (right column)	0, 1	<p>Indicates whether the alarm is latching (1) or not latching (0). According to EN 60079-29-1, chapter 4.3.3.2 the lowest alarm shall only be configured as not latching. A not latching alarm stops if the alarm condition is no longer present. Please keep in mind the alarm hysteresis (see 4.8.2). A latching alarm has always to be reset manually (see 5.3).</p>
Channel Fault (F, right column)	0, 1	<p>Indicates whether the channel fault is latching (1) or not latching (0).</p> <p>A not latching channel fault stops if the alarm condition is no longer present.</p> <p>A latching channel fault has always to be reset manually (see 5.3).</p>

You can also connect ExTox smoke detectors to the ET-8D and ET-4D2 (see 10). In this case different procedures have to be considered.

Series ET-8D: The smoke detector function is activated with parameter "RM" in the gas list. Please select "100" as measuring range. The alarm levels have to be adjusted to "10", "11" and "12". Please pay attention to the hints for operation and installation of smoke detectors in Chapters 5.11 and 8.3.

Series ET-4D2: For configuration of channel "RM" has to be selected as gas type. All further settings in channel configuration are ignored for smoke detector measuring channels.

Connection of a smoke detector should only be done on measuring channels which have especially been prepared factory-sided. Connections on the PCB are marked correspondingly. The smoke detector function is activated with parameter "RM" in the gas list. Please pay attention to the hints for operation and installation of smoke detectors in Chapters 5.11 and 8.3.

4.2 Relay Configuration

Access Level to perform changes of the parameter settings: 2

Menu Text	Selection	Function
Relay	1 to 24 (12)	Selection of Relay for which the triggering conditions should be fixed.
Reset	On, Off	Indicates that the relay could be reset manually in case the triggering conditions are still fulfilled (On). But the relay is triggered again, if the triggering conditions are fulfilled again due to another alarm or another fault ("re-triggering of alarms", see 5.3). <i>Attention:</i> This function shall only be used for quitting an acoustic message. Otherwise the relay is reset automatically if the triggering condition is no longer fulfilled (Off).
Mode	(+), (-)	Indicates whether the relay closes (+) or opens (-) on presence of triggering conditions. -: the relay closes in measuring operation if there is no alarm or fault. +: the relay is open in measuring operation if there is no alarm or fault. The setting determines whether an alarm is triggered (-) or not triggered (+) at the control unit in case of a loss of power supply. Independently of that you fix by choosing the change-over contact whether you use the closed current or the operating current principle for the connected peripheral devices. In safety orientated connections the mode (-) in combination with the closed current principle is generally used. For operation of optical or acoustic indicators the mode (+) is selected.
Logic	OR, AND	OR: The alarms or faults selected in the matrix are always logically-OR linked, that means presence of an alarm or a fault leads to the triggering of the relay. AND: The alarms or faults selected in the matrix are logically-AND linked, that means the relay is triggered only on simultaneous triggering of all alarms and faults.

Menu Text	Selection	Function																														
Matrix settings Channel / A1 A2 A3 F	0, 1	<p>Indicates whether the alarm or the channel fault is considered when evaluating the triggering condition (1) or not (0).</p> <p>Example: Channel 1, 2. Alarm, Channel 2, Fault or Channel 3, 3. Alarm trigger the relay:</p> <table style="margin-left: 40px;"> <thead> <tr> <th></th> <th>K1</th> <th>K2</th> <th>K3</th> <th>K4</th> <th>...</th> </tr> </thead> <tbody> <tr> <td>AI1</td> <td>0</td> <td>0</td> <td>0</td> <td>0</td> <td>...</td> </tr> <tr> <td>AI2</td> <td>1</td> <td>0</td> <td>0</td> <td>0</td> <td>...</td> </tr> <tr> <td>AI3</td> <td>0</td> <td>0</td> <td>1</td> <td>0</td> <td>...</td> </tr> <tr> <td>F</td> <td>0</td> <td>1</td> <td>0</td> <td>0</td> <td>...</td> </tr> </tbody> </table>		K1	K2	K3	K4	...	AI1	0	0	0	0	...	AI2	1	0	0	0	...	AI3	0	0	1	0	...	F	0	1	0	0	...
	K1	K2	K3	K4	...																											
AI1	0	0	0	0	...																											
AI2	1	0	0	0	...																											
AI3	0	0	1	0	...																											
F	0	1	0	0	...																											

Standard Configuration *Series ET-8D* at delivery:

- Relay 1 to 8: 1. Alarm of Channels 1 to 8, Mode (-), Logic: OR, Reset: OFF
- Relay 9 to 16: 2. Alarm of Channels 1 to 8, Mode (-), Logic: OR, Reset: OFF
- Relay 17 to 20: not engaged
- Relay 21: 1. Collective Alarm Channels 1 to 8, Mod (-), Logic: OR, Reset: OFF (not valid for operation with smoke detector, in this case internally occupied, see 8.3)
- Relay 22: 2. Collective Alarm Channels 1 to 8, Mode (-), Logic: OR, Reset: OFF
- Relay 23: 3. Collective Alarm Channels 1 to 8, Mode (-), Logic: OR, Reset: OFF
- Relay 24: Collective Fault Channels 1 to 8, Mode (-), Logic: OR, Reset: OFF

Standard Configuration *Series ET-4D2* at delivery:

- Relay 1 to 4: 1. Alarm of Channels 1 to 4, Mode (-), Logic: OR, Reset: OFF
- Relay 5 to 8: 2. Alarm of Channels 1 to 4, Mode (-), Logic: OR, Reset: OFF
- Relay 9: 1. Collective Alarm Channels 1 to 4, Mode (-), Logic: OR, Reset: OFF
- Relay 10: 2. Collective Alarm Channels 1 to 4, Mode (-), Logic: OR, Reset: OFF
- Relay 11: 3. Collective Alarm Channels 1 to 4, Mode (-), Logic: OR, Reset: OFF
- Relay 12: Collective Fault Channels 1 to 4, Mode (-), Logic: OR, Reset: OFF

Please see attached test certificate for configuration at delivery.

4.3 Calibration

This menu item is not activated in the herein described mode of the ET-8D and ET-4D2 (see 4.8.5). The menu can not be selected.

4.4 Time/Date

Access Level to perform changes of the parameter settings: 1

Menu Text	Selection	Function
HH	0 to 23	Hour of Control Unit time, changes via F2/F3 (+/-) <i>Attention:</i> The real time clock of the control unit does not automatically switch between summer and winter time. The clock is battery backed. If date and time are not displayed automatically after lapse of power supply and re-initiation, this data could be entered manually. The safety functions are not affected but the batteries should be exchanged on the next maintenance done by ExTox.
MM	0 to 59	Minutes of Control Unit time, changes via F2/F3 (+/-)
SS	0 to 59	Seconds of Control Unit time, changes via F2/F3 (+/-)
TT	01 to 31	Day of Control Unit date, changes via F2/F3 (+/-)
MM	01 to 12	Month of Control Unit date, changes via F2/F3 (+/-)
JJ	00 to 99	Year of Control Unit date, changes via F2/F3 (+/-)

4.5 Analogue Inputs

Within this menu it is impossible to change any parameters.

4.5.1 Series ET-8D

Menu Text	Selection	Function
Selection via F1 (20mA): Analogue Inputs 4..20 mA		
CH1 to CH8	0.00 to 25.00 mA	The actual value of the transmitter output current which is pending at the entry of the control unit prior to processing is displayed.
Selection via F4 (U_{int}): Analogue Inputs U_{int}		
V_{cc}		4.75 V ... 5.25 V: internal power supply (digital)
U_{Batt}		2.00 V ... 4.50 V: battery power of real time clock
+24 V		20.00 V ... 27.00 V: power supply control unit
+24 V Rel		20.00 V ... 27.00 V: power supply relays
+24 V int		20.00 V ... 27.00V: internal power supply
V+		18.00 V ... 24.00 V: power supply analogue outputs
V-		-4.50 V ... -5.50 V: internal auxiliary supply
n.u.		Not used

Only type ET8-DA: For testing purposes (only in menu U_{int} and in Access Level 3) constant values can be issued at the analogue outputs via SHIFT+F2. Starting at Channel 1 with 4 mA, the output current increases with rising channel number in steps of 1 mA. In consequence Channel 8 issues 11 mA. The test function can be left via SHIFT+F3.

4.5.2 Series ET-4D2

Menu Text	Selection	Function
Selection via F1 (20mA): Analogue Inputs 4..20 mA		
CH1 to CH4	0.00 to 25.00 mA	The actual value of the transmitter output current which is pending at the entry of the control unit prior to processing is displayed.
Selection via F4 (U _{int}): Analogue Inputs U _{int}		
V _{cc}		4.75 V ... 5.25 V: internal power supply (digital)
U _{Batt}		2.00 V ... 4.50 V: battery power of real time clock
+24 V		20.00 V ... 27.00 V: power supply control unit
+24 V Rel		20.00 V ... 27.00 V: power supply relays

Only type ET4-DA2: For testing purposes (only in menu U_{int} and in Access Level 3) constant values can be issued at the analogue outputs via F6+F2. Starting at Channel 1 with 4 mA, the output current increases with rising channel number in steps of 1 mA. In consequence Channel 4 issues 7 mA. The test function can be left via F6+F3.

4.6 Adjustment

This chapter describes the adjustment of transmitters at the control unit.

The Control Units are in general used with transmitters which dispose of a linear 4-20 mA output that means the current input of 4 mA is interpreted as zero point and the input current of 20 mA as end value of measuring range. In between conversion is done linear according to the following formula:

$$\text{Measured value} = \frac{\text{Measured current} - 4 \text{ mA}}{16 \text{ mA}} \cdot \text{End value of measuring range}$$

Corrections of settings are done at the transmitter itself and not at the control unit.

In case this is impossible, such as for example due to the fact that the transmitter is hardly accessible for maintenance purposes, both control units offer the possibility of a device internal adjustment. To perform this, the measured current value is converted with an offset and a gain factor after recording of the transmitter signal. After that formation and evaluation of the measured value are done. Necessary settings can be performed in the menu points OFFSET and GAIN. These corrections correspond to the adjustment of zero point and sensitivity at the transmitter itself.

Attention: The range of correction values is limited to restrict the adjustment to convenient tolerance range as far as measuring techniques are concerned. Further corrections have to be performed directly at the corresponding transmitter, where required the sensor element has to be exchanged.

The adjustment is done in two steps. During application of zero gas first of all the offset is changed until the actual value indicated on the display is 4 mA or 0. Then the gain is adjusted while applying test gas until the actual value indicated on the display corresponds to the nominal value.

Attention: In case a measuring point is selected for adjustment, the actual alarm status is frozen. Alarm and fault messages are neither re-triggered nor deleted, as long as this measuring point is in adjustment. When changing the measuring point or leaving the adjustment menu status is actualised.

Access Level to perform changes of the parameter settings: 3

Menu Text	Selection	Function
Channel	1 to 8 (4)	Selection of the channel to be adjusted
Gain	0.500 to 2.000	Correction value for gain. Explication within the text above. Value 1.000 will not be corrected.
Offset [mA]	-2.000 to 2.000	Correction value for zero point. Explication within the text above. Value 0.000 will not be corrected.
Act. Value [mA]	0 to 25 mA	The input current corrected in Offset and Gain is displayed.
Act. Value	Measured Value	The measured value evaluated by the control unit <u>after</u> correction is displayed.

Attention: a gain of < 1 limits the effectively useable measuring range. On a minimal gain of 0.5 it is only 50 % of the original measuring range. When selecting the alarm levels please ensure that they can still be triggered safely. For complete use of the adjustment range ExTox therefore recommends to avoid alarm levels > 50 % of the measuring range.

Description of the Adjustment Process

The formula mentioned above to convert the measuring value changes when using this form of adjustment. It is then:

$$\text{Measured value} = \frac{(\text{Measured current} + \text{Offset}) - 4 \text{ mA}}{16 \text{ mA}} \cdot \text{Gain factor} \cdot \text{End value of measuring range}$$

4.7 Password

In this menu the password protected levels could be released.

Menu Text	Selection	Function
Access Level 1,2,3:	Locked, Released	Indicates, whether the access of the access level is right now released or locked.
Access Level 1,2,3	**** 0000 to 9999	A level is reached by entering the four figured password. Therefore the password is entered for the four figure positions via the respective functional keys, for example "0x00" for the second figure position. When all of these four figures are correctly entered, please change the access level by pressing "^v". During this process the entered password is checked and the level is released on positive result (indication see above). A release can be reversed by entering a wrong password in the respective level. <i>Remark:</i> The display only shows the actually entered figure. All other positions show "0" or "*" to ensure the confidentiality of the access.

Attention: 10 Minutes after the latest entering from side of the user or after quitting the service mode (see 4.8.1) the release is automatically cancelled.

4.8 System Parameters

This menu consists of eight submenus. The software version is additionally displayed on top on the right side.

4.8.1 Maintenance

Access level to activate the service mode: 1

The activation of maintenance functions in this menu is indicated by means of the blinking operation LED and the relay K26 and K14 (Maintenance) is not engaged.

The service mode for all channels can also be activated via the digital input E4, for example by a circuit with an external key-switch.

The service mode can actively be quit by pressing the functional key END in the maintenance menu otherwise it will automatically be left ca. 60 minutes after the latest input at the control unit.

Menu Text	Selection	Function
LED-Test	OFF, ON	In the case of LED-Test ON all LEDs will be switched on. In case of LED-Test OFF all LEDs will be switched off. After 2 s it is returned to the normal indication.
Channel	0000... to 1111... (figure wise)	In this number every figure represents one of the channels 1 to 8 (ET-8D) or 4 (ET-4D2), starting left with Channel 1. Figure 0 means the channel is in measuring operation. By adjusting the value 1 the channel can be put into service. For the duration of maintenance all alarm and fault messages are blocked for this channel. You could at the same time put more channels into service. After selection of one or more channels you could enter the other menus without cancelling the service mode. The blinking Operation-LED of a channel indicates that the channel is in maintenance mode. The service mode can actively be quit by pressing the functional key END in the maintenance menu.
Matrix Settings (right side)	0, 1	<i>Relay Test:</i> The relay setting can be changed for a short time by manual selection. The relay is switched for ca. 1.5 s and then it returns to the former condition.
Top Line I1= ... I4=...	0, 1	The actual status of the potential free digital inputs is indicated. In case of current (> 20 V) status 1 is indicated. In case of no current (< 5 V) status 0 is indicated.

4.8.2 Inputs 4...20 mA

Access Level to perform changes of the parameter settings: 3

Menu Text	Selection	Function
Hysteresis	0 % to 20 %	<p>Fixes the alarm hysteresis in percent of the end value of measuring range. A non latching alarm expires only when it is around the value of hysteresis below the alarm level. This function serves for prevention of permanent repeating of alarm triggering due to slight variations of measured values around the alarm level.</p> <p>Example: Measuring range 100 ppm, Hysteresis 3 %, Alarm level 10 ppm. The alarm does not expire until 7 ppm is under run.</p> <p>Standard setting: 0 %</p> <p><i>Attention:</i> combination of low alarm levels with too high hysteresis values may lead to a very late reset or even non-reset of alarms.</p>
I_{\min}	1.0 mA to 3.0 mA	<p>Fixes the level at which a channel fault is indicated by means of the transmitter input current in case of under-run. The setting has to be chosen that way that fault conditions of connected transmitters can be recognized safely. Therefore the value has to higher than all transmitter output currents indicating fault conditions. Please pay attention to the remarks in the Transmitter Instruction Manual.</p> <p>Standard setting for ExTox-Transmitters = 1.5 mA</p>
I_{\max}	21.0 mA to 24.5 mA	<p>Fixes the level at which a channel fault is indicated by means of the transmitter input current in case it is exceeded.</p> <p>Standard setting for ExTox-Transmitters = 22.5 mA</p>
NPC	0 to 5 %	<p>The attenuation of the zero point can be set. In the range 0 to + NPC of the end value of measuring range the value is indicated on 0. In the next range up to + 2·NPC of the end value of measuring range a smooth approach to the linear calibration curve will take place, which is valid from + 2 NPC on. The negative range is treated inversely in the same way.</p> <p>By this slight fluctuations in zero point can be suppressed in the indication without changing the indication performance as far as the alarm levels are concerned. Please note that the alarm levels should not be in the range up to + 2·NPC of end value of measuring range.</p> <p>Standard setting: 0 %, i. e. deactivated.</p>
Delay A1, A2, A3, F	0 s to 60 s	<p>A triggering delay can be adjusted for the alarm levels and transmitter fault.</p> <p>Standard setting: 0 s</p>

Menu Text	Selection	Function
20mA-H(old)	OFF, ON	<p>This function enables the suppression of alarm triggering by means of external peripheral devices, for example SPS, in case the gas detection system is in service mode.</p> <p>Only valid for types with analogue outputs (ET-8DA and ET-4DA2): In case this parameter is activated (ON) the analogue output of the corresponding measuring channel is frozen (see 5.9) when passing to the service mode (see 4.8.1). Indication of measured values, messages, relay outputs work as in normal measuring operation. After leaving the service mode the analogue output is actualised.</p> <p>In case this parameter is deactivated (OFF), the analogue output follows the actual measured values even in service mode.</p> <p>Standard setting: OFF.</p>
Imin>=4mA (Imin=4mA)	OFF, ON	<p>In standard setting OFF the performance of the analogue output during measuring operation corresponds to the performance described in Chapter 5.9.</p> <p>In case the setting ON is selected all output values < 4 mA are indicated on the output current 4 mA and all output values > 20 mA are indicated on the output current 20 mA. This function in combination with external controls, which process only input of measured values ≥ 4 mA correctly, helps to avoid malfunction. <i>Attention:</i> negative zero point drift or transmitter fault can not be recognised any longer by the external control at this output.</p>

4.8.3 Memory Test

Within this menu it is impossible to change any parameters.

4.8.3.1 Series ET-8D

Menu Text	Selection	Function
RAM	-	<p>Indication of the RAM-Test status:</p> <ol style="list-style-type: none"> 1. Line: Address in Test 2. Line (BAD): 0000 or defective RAM cell 3. Line: - 4. Line: OK or ERROR (Status of Test)
ROM	-	<p>Indication of the ROM-Test status:</p> <ol style="list-style-type: none"> 1. Line: Address in Test 2. Line (CKS): latest checksum 3. Line: Nominal value of checksum 4. Line: OK or ERROR (Status of Test)
EEPROM	-	Indication of the ROM-Test status: see ROM

4.8.3.2 Series ET-4D2

Menu Text	Selection	Function
RAM	-	Indication of RAM-Test status: OK or ERROR (Status of Test)
ROM	-	Indication of ROM-Test status: OK or ERROR (Status of Test)
EEPROM	-	Indication of ROM-Test status: OK or ERROR (Status of Test)

4.8.4 Language

Access Level to perform changes of parameter settings: none

Menu Text	Selection	Function
Language	D, GB	Selection of language for configuration menus and display indication in normal operation.

Other language versions on request.

4.8.5 Mode

Access Level to perform changes of parameter settings: 3

Menu Text	Selection	Function
Mode	ET-8 (ET-4), IMC, BIO usw.	In standard setting "ET-8" or "ET-4" shows the behaviour described in this Instruction Manual. The other settings are only activated in case the control units are used in ExTox Integral Measuring Concepts IMC. The additional function supplements and deviations are described in the IMC Instruction Manual. <i>Attention:</i> The user is in no way allowed to perform any change of this setting. Changed measuring functions may otherwise lead to the loss of safety functions.

4.8.6 Options

Access Level to perform changes of parameter settings: 3

Menu Text	Selection	Function
RS232	0, 1, 2, A...P	On ET-8D these settings can be performed for both Interfaces RS232/1 and RS232/2. 0: Data output via RS232 (see 6) is deactivated. 1: Measured values and status messages are put out cyclically in intervals of 10 s. 2: Configuration of system parameters via PC (can only be used with ExTox-Service-Software) A...P: Setting of address for external ExTox-Visualisation ET-View / ET-Diag (Systems with ProfiBus- or ModBus-connection offer further selection possibilities, which are described in the corresponding amendments to the Instruction Manual.)
RS232	OFF, ON	OFF: Data output via RS232 (see 6) is deactivated. ON: Measured values and status messages are put out cyclically in intervals of 10 s.
All remaining settings are only activated in case the control units are used in ExTox Integral Measuring Concepts IMC. Corresponding functional amendments and differences are described in a separate IMC-Instruction Manual.		

4.8.7 AQUIT

Access Level to perform changes of parameter settings: 3

Menu Text	Selection	Function
AQUIT	Off, On	It can be set whether alarm reset is possible with or without password release. ON: alarm reset is possible without password release (standard setting). OFF: alarm reset is only possible with release of level 2 or higher (see 4.7).

4.8.8 Alarm

Within this menu it is impossible to perform any changes of parameters.

The latest 15 changes of status on evaluation of alarms, transmitter and device fault can be read out. All data are permanently stored and are available even after power failure.

In the headline date and time of change of status are documented. The first column of the table indicates the condition of alarms and faults for the eight or four measuring channels after change of status. The second column shows a list of the device internal conditions for tension and memory. Value 1 symbolises the activated condition.

Reset of the list can only be done via F5+F6 in Access Level 3.

5 Operation of the Control Unit

The features which especially mark the measuring modes are emphasised by heavy print in the following chapters.

5.1 Measuring Mode

There are no faults and alarms. The measured value is within the range between 0 % and 100% of the end value of measuring range.

Please note that evaluation of the measured value is only done after zero point attenuation has been carried out (unless activated according to 4.8.2). The real transmitter input current and with it the unprocessed raw signal can always be seen by selecting the menu analogue inputs (4.5).

Status-LEDs

Channel Fault (yellow):	off
Alarm 1, 2, 3 (red):	off
Operation of Channel:	on, if channel activated
Operation:	on
Fault Control Unit:	off

Display

Bar Graph:	actual value within the range 0 to end value of measuring range
Actual Value:	actual measured value within the range 0 to end value of measuring range
Alarm A1, A2, A3:	0
Fault F:	0

Relays ET-8D (for ET-4D2 in brackets)

K1 to K24 (K12):	not triggered
Fault Control Unit K25 (K13):	closed
Maintenance K26 (K14):	closed

5.2 Deactivation of Channel

A channel can temporarily be taken out of monitoring, for example if works on the transmitter have to be performed which might lead to false alarms.

To deactivate a channel it has to be selected in the bar graph indication of the display. By pressing the functional keys SHIFT+F4 (ET-8D) or F6+F1 (ET-4D2) it can now be deactivated. By pressing SHIFT+F5 (ET-8D) or F6+F2 (ET-4D2) the channel can be put into operation mode again.

Attention: This function should only be used if a gas hazard can definitely be excluded.

Status-LEDs

Channel Fault (yellow):	off
Alarm 1, 2, 3 (red):	off
Operation of Channel:	off
Operation:	on
Fault Control Unit:	off

Display

Bar Graph:	0
Actual Value:	0
Alarm A1, A2, A3:	0
Fault F:	0

Relays ET-8D (for ET-4D2 in brackets)

K1 to K24 (K12): not triggered
Fault Control Unit K25 (K13): closed
Maintenance K26 (K14): closed

5.3 Alarms

Minimum one configured alarm on one channel level is triggered.

If the alarm is configured as latching, it has to be reset manually in case the alarm condition is no longer available.

Series ET-8D: for that purpose the *bar graph and detail indication* has to be activated (see Chapter 3). Now the corresponding channel has to be selected on the display and then the alarm A1, A2, A3 to be reset by means of the functional keys F3 (<AL) or F4 (AL>). The alarm can now be cleared by means of the functional key F5 (AQUIT).

Series ET-4D2: for that purpose the *bar graph and detail indication* has to be activated. Now the corresponding channel has to be selected on the display by using functional key F1 (<CH>) and then the alarm A1, A2, A3 to be reset by means of the functional key F2 (<AL>). By means of functional key F3 (AQUIT) the alarm can now be cleared.

In case of setting the parameter AQUIT=OFF (see 4.8.7) it is only possible to quit the alarm if you have released access level 2 or 3 before.

Relays which can be reset - see Chapter 4.2 -, can be quit by pressing the functional key F7 (ET-8D) or F5 (ET-4D2). But the *bar graph and detail indication* has to be selected. In general this function is only used for acoustic messages, such as for example horn, buzzer. Please see the description in Chapter 4.2 concerning re-triggering in case of an additional alarm (re-triggering of alarm).

Status-LEDs

Channel Fault (yellow): off
Alarm 1, 2, 3 (red): on, for triggered alarms
Operation of Channel: on, if channel activated
Operation: on
Fault Control Unit: off

Display

Bar Graph: actual value within the range 0 to end value of measuring range
Actual Value: actual measured value within the range 0 to end value of measuring range

Alarm A1, A2, A3: 1 for triggered alarms, otherwise 0
Fault F: 0

Relays ET-8D (for ET-4D2 in brackets)

K1 to K24 (K12): triggered, if alarm condition contains activated alarms.
Fault Control Unit K25 (K13): closed
Maintenance K26 (K14): closed

5.4 Under-Scale and Over-Scale of Measuring Range

The measured value is within the range below 0 % and above 100% of the end value of measuring range. Please note that evaluation of the measured value is only done after zero point attenuation has been carried out (unless activated according to 4.8.2).

In case of Under-Scale of measuring range measures for correction of Zero Point should be taken. The deviation value could be evaluated in the menu Analogue Inputs (4.5) by means of the transmitter input current.

In case of Over-Scale of measuring range due to high gas concentrations corresponding maintenance measures for the individual transmitter should be taken on short notice, such as for example calibration and adjustment.

Attention: For transmitters based on the measuring principle catalytic combustion and semiconductor the sensor signal might fall again into the measuring range due to the suppression of oxygen at very high concentrations of flammable gases. When using ExTox-Transmitters safe measurement is ensured when configuring the channel fault as latching (see 4.1). In case of Over-Scale of measuring range the indication of bar graph and measured value remain at a value above the end value of measuring range, even in case the transmitter signal falls again.

The indication of bar graph and measured value are actualised if the Over-Scale of measuring range is quit by pressing functional key F5 or F3 (AQUIT) (activated latching alarms have then to be quit independently according to 5.3.).

In any way please check before quitting the alarm that the gas concentration is really below the alarm levels again.

Status-LEDs

Channel Fault (yellow):	off
Alarm 1, 2, 3 (red):	on, for triggered alarms
Operation of Channel:	on, if channel activated
Operation:	on
Fault Control Unit:	off

Display

Bar Graph:	respective to 0 or end value of measuring range
Actual Value:	< 0 or > End Value of Measuring Range
Alarm A1, A2, A3:	1 for triggered alarms, otherwise 0
Fault F:	0 (or 1 for latching fault acc. to 5.5)

Relays ET-8D (for ET-4D2 in brackets)

K1 to K24 (K12):	triggered, if alarm condition contains activated alarms.
Fault Control Unit K25 (K13):	closed
Maintenance K26 (K14):	closed

5.5 Channel Fault

The input current of the transmitter is outside the limits fixed in the system parameters (4.8.2), that means the (un-processed) transmitter input current is below I_{\min} or above I_{\max} .

Reason for that might in general be a transmitter fault, interruption of transmitter power supply, interruption or short circuit of transmitter cable.

If the channel fault is configured as latching, it has to be reset manually in case the alarm condition is no longer available.

Series ET-8D: for that purpose the *bar graph and detail indication* has to be activated (see Chapter 3). Now the corresponding channel has to be selected on the display and then the fault F to be reset by means of the functional keys F3 (<AL) or F4 (AL>). The fault can now be cleared by means of the functional key F5 (AQUIT).

Series ET-4D2: for that purpose the *bar graph and detail indication* has to be activated. Now the corresponding channel has to be selected on the display by using functional key F1 (<CH>) and then the fault to be reset by means of the functional key F2 (<AL>). By means of functional key F3 (AQUIT) the fault can now be cleared.

In case of setting the parameter AQUIT=OFF (see 4.8.7) it is only possible to quit the fault if you have released access level 2 or 3 before.

Attention: In application for explosion protection the channel fault has to be appointed to minimum one relay, for example in a collective message. In our standard configuration (4.2) relay 24 (ET-8D) or relay 12 (ET-4D2) is engaged correspondingly

Status-LEDs

Channel Fault (yellow):	on for the respective channel
Alarm 1, 2, 3 (red):	on for triggered alarms
Operation of Channel:	on, if channel activated
Operation:	on
Fault Control Unit:	off

Display

Bar Graph:	respective to 0 or end value of measuring range
Actual Value:	<< 0 or >> End Value of Measuring Range
Alarm A1, A2, A3:	1 for triggered alarms, otherwise 0
Fault F:	1

Relays ET-8D (for ET-4D2 in brackets)

K1 to K24 (K12):	triggered, if alarm condition contains activated alarms.
Fault Control Unit K25 (K13):	closed
Maintenance K26 (K14):	closed

5.6 Fault of Control Unit

A fault of Control Unit is indicated in case the internal power monitoring or memory test issues a fault.

Attention: the fault of control unit and the fault of individual transmitters are differed to allow a differentiated concept for reaction on faults. Please pay attention to the fact that both message types are suitably processed in your concept.

The control unit tries to continue normal operation, especially messages and relays are not reset. But it cannot be excluded that the control unit may adapt undefined states depending on cause of fault.

The fault of control unit is non-latching, that means the control unit continues normal operation in case of return to the admissible voltage range or in case of faultless passing the memory test.

Please check the power supply of the device. In case of a memory fault please contact the ExTox-Service.

Attention: Please keep in mind that in case of a fault of control unit not all relays are reset. Please include the relay Fault Control Unit K25 (K13) suitably into your safety concept so that a loss of safety function is recognized.

Status-LED

Fault Control Unit:	on
---------------------	----

Relays ET-8D (for ET-4D2 in brackets)

Fault Control Unit K25 (K13):	open
-------------------------------	------

(With the exception of the described reactions the system status can be undefined.)

5.7 Programme Run Monitoring (Watchdog)

The control unit disposes of a programme sequence monitoring by means of a Watchdog element working independently. In case this watchdog recognizes an interruption of the regular course it triggers a reset of the control unit. Then the initialisation (5.8) is passed.

If the control unit does not enter normal operation again, please contact the ExTox-Service.

5.8 Initialisation (Start-up of System)

After connecting the control unit to the power supply it is passing an initialisation phase. The display indicates patterns during that time. After that the company name and the Internet Address of ExTox are indicated on the start screen for 120 seconds. The remaining time until starting normal operation a countdown running downwards is displayed.

For devices with analogue outputs the value 2.5 mA is issued for all measuring channels. At the same time the complete memory (RAM/ROM/EEPROM) is checked. This test is cyclically repeated during the measuring mode (see 4.8).

5.9 Analogue Outputs 4...20 mA (only Types ET-8DA and ET-4DA2)

A current corresponding to the transmitter measured value is issued at the analogue outputs as long as it is in the range between I_{\min} to I_{\max} (see 4.8.2). Transmitter input currents $< I_{\min}$ or input currents $> I_{\max}$ are indicated at the analogue outputs of the control unit on I_{\min} or I_{\max} .

In case of a channel fault I_{\min} or I_{\max} is always issued.

Please pay attention to the fact that the output current must not correspond to the input current of the transmitter due to the evaluation of measured values.

In case of deactivated channels a current of 2.5 mA is constantly issued.

5.10 Digital Inputs

The digital input E4 can be used for external activation of the service mode for all channels (see 4.8.1). In case there is an impressed current (> 20 V) the service mode is set for all measuring points. In case there is no impressed current (< 5 V), the measuring operation is continued. *Attention:* please note that the monitoring function is deactivated in service mode. An external activation is due to that only allowed if full and actual knowledge of the predominant situation in the monitored area are available. The feature should only be used if it matches with the safety concept of your application.

The digital inputs E1 to E3 are normally without function, but they can be used for customer specific requirements. On demand please do not hesitate to contact ExTox.

5.11 Smoke Detectors

Please pay attention to the differences between the two control unit types ET-8D and ET-4D2.

5.11.1 Series ET-8D

The optical smoke detector DP721R (Art.-No. 297000) can be connected to the ET-8D (see 10). For channel configuration the settings described in Chapter 4.1 have to be used.

Alarms triggered by the smoke detector are always latching due to the internal connection. Reset is done by pressing the keys SHIFT and F7/QUIT simultaneously.

5.11.2 Series ET-4D2

The optical smoke detector DP721R (Art.-No. 297000) can be connected to the ET-4D2, if the corresponding measuring channel has been configured accordingly.

Configuration is done factory-sided before delivery and is especially marked on the test certificate (in case an existing system should be converted please do not hesitate to contact the ExTox-Service.).

For configuration of channel "RM" has to be selected as gas type. All further settings in channel configuration are ignored for smoke detector measuring channels.

If the smoke detector triggers, only the 1st Alarm is activated at the ET-4D2. The alarm is latching.

Reset of a smoke detector is done in the same way as for a normal measuring channel (see 5.3).

5.12 RS 485-Interfaces for Transmitter ExSens-I and Sens-I

For communication with the transmitters ExSens-I and Sens-I via RS 485-Interface the following clamp connections A and B (\varnothing DB) should be used at the clamp for the measuring channel. The separate clamp pair on the PCB for RS 485-Interface cannot be used.

6 Digital Data Output

The data output via RS232 enables to send all measured values and status messages cyclically every 10 s via the serial Interface to a periphery, such as for example to a PC. This data transfer has to be activated in the menu System Parameters (see 4.8).

Data Output via RS232-Interface, Profibus[®] DP and ModBus[®] has not been part of the EC-Type Test for measuring technical function. Use of this data is for information and storing purposes, but not for safety functions.

It is possible to record the data by means of an ExTox Data Logger ET-SL which is available as accessory (see Chapter 10).

Corresponding Interface Modules (Art.-No. 825009 or 825017) are available for integration in a Profibus DP- or a ModBus-environment. The specification of the interface is described in Chapter 6.4. Additional bus systems on request.

6.1 Data Formate

All measured values and texts are sent in ASCII-Format, each separated by a semicolon. Every single data set is completed by a CR (\$0D). This formatting enables to import recorded data sets as raw file for example in Microsoft EXCEL[®] and to process later on. To do this please use assistant for text conversion of EXCEL[®]. As separator please choose the semicolon.

6.2 Parameters of Serial Data Transfer

Data Formate:	Assignment of the Connector:
38.4 kBd (Series ET-8D), 9.6 kBd (Series ET-4D2)	Pin 2 - ET-8D: TxD, ET-4D2: RxD
8 Data-Bits	Pin 3 - ET-8D: RxD, ET-4D2: TxD
1 Stop-Bit	Pin 5 - GND
No parity, no Handshake	

6.3 Composition of recorded Data

This description is based on the data evaluation via Microsoft EXCEL®.

6.3.1 Series ET-8D

Column	Content	Format	Example	Explanation
A:	Date	ASCII	08.01.2005	TT.MM.JJJJ
B:	Time	ASCII	12:23:00	HH:MM:SS
C:	Channel 1 Gas	ASCII	CH4	Denomination of measurand in clear text
D:	Channel 2 Gas	ASCII	O2	
E:	Channel 3 Gas	ASCII	---	
F:	Channel 4 Gas	ASCII	---	
G:	Channel 5 Gas	ASCII	H2S	
H:	Channel 6 Gas	ASCII	Temp	
I:	Channel 7 Gas	ASCII	Temp	
J:	Channel 8 Gas	ASCII	pH	
K:	Channel 1 Dimension	ASCII	% (v/v)	Unit of measurand
L:	Channel 2 Dimension	ASCII	% (v/v)	
M:	Channel 3 Dimension	ASCII	% (v/v)	
N:	Channel 4 Dimension	ASCII	% (v/v)	
O:	Channel 5 Dimension	ASCII	ppm	
P:	Channel 6 Dimension	ASCII	Grad	
Q:	Channel 7 Dimension	ASCII	Grad	
R:	Channel 8 Dimension	ASCII	pH	
S:	Channel 1 Range	ASCII	100,0	Measuring range of channel with and without decimal place
T:	Channel 2 Range	ASCII	25.0	
U:	Channel 3 Range	ASCII	1000	
V:	Channel 4 Range	ASCII	1000	
W:	Channel 5 Range	ASCII	3000	
X:	Channel 6 Range	ASCII	100.0	
Y:	Channel 7 Range	ASCII	100.0	
Z:	Channel 8 Range	ASCII	14.0	
AA:	Channel 1 Value	ASCII	54.0	Measured value of channel with and without decimal place
AB:	Channel 2 Value	ASCII	5.3	
AC:	Channel 3 Value	ASCII	0.0	
AD:	Channel 4 Value	ASCII	0.0	
AE:	Channel 5 Value	ASCII	230	
AF:	Channel 6 Value	ASCII	22.6	
AG:	Channel 7 Value	ASCII	22.8	
AH:	Channel 8 Value	ASCII	7.7	
AI:	Channel 1 ALARM 1	ASCII	1	Alarm status of channel 0 = no Alarm 1, 1 = Alarm 1
AJ:	Channel 2 ALARM 1	ASCII	0	
AK:	Channel 3 ALARM 1	ASCII	0	
AL:	Channel 4 ALARM 1	ASCII	0	
AM:	Channel 5 ALARM 1	ASCII	0	
AN:	Channel 6 ALARM 1	ASCII	0	
AO:	Channel 7 ALARM 1	ASCII	1	
AP:	Channel 8 ALARM 1	ASCII	0	
AQ:	Channel 1 ALARM 2	ASCII	0	Alarm status of channel 0 = no Alarm 2, 1 = Alarm 2
AR:	Channel 2 ALARM 2	ASCII	0	
AS:	Channel 3 ALARM 2	ASCII	0	
AT:	Channel 4 ALARM 2	ASCII	0	
AU:	Channel 5 ALARM 2	ASCII	0	
AV:	Channel 6 ALARM 2	ASCII	0	
AW:	Channel 7 ALARM 2	ASCII	0	
AX:	Channel 8 ALARM 2	ASCII	0	
AY:	Channel 1 ALARM 3	ASCII	0	Alarm status of channel 0 = no Alarm 3, 1 = Alarm 3
AZ:	Channel 2 ALARM 3	ASCII	0	
BA:	Channel 3 ALARM 3	ASCII	0	
BB:	Channel 4 ALARM 3	ASCII	0	
BC:	Channel 5 ALARM 3	ASCII	0	
BD:	Channel 6 ALARM 3	ASCII	0	
BE:	Channel 7 ALARM 3	ASCII	0	
BF:	Channel 8 ALARM 3	ASCII	0	
BG:	Channel 1 FAULT	ASCII	0	Channel fault 0 = no fault,
BH:	Channel 2 FAULT	ASCII	0	

Column	Content	Format	Example	Explanation
BI:	Channel 3 FAULT	ASCII	0	1 = fault; This stands for transmitter faults, such as for example defects of the transmitter cable.
BJ:	Channel 4 FAULT	ASCII	0	
BK:	Channel 5 FAULT	ASCII	0	
BL:	Channel 6 FAULT	ASCII	0	
BM:	Channel 7 FAULT	ASCII	0	
BN:	Channel 8 FAULT	ASCII	0	
BO:	Channel 1 MODE	ASCII	0	Operation status of channel 0 = Channel deactivated, 1 = Channel activated
BP:	Channel 2 MODE	ASCII	0	
BQ:	Channel 3 MODE	ASCII	0	
BR:	Channel 4 MODE	ASCII	0	
BS:	Channel 5 MODE	ASCII	0	
BT:	Channel 6 MODE	ASCII	0	
BU:	Channel 7 MODE	ASCII	0	
BV:	Channel 8 MODE	ASCII	0	
BW:	System Mode	ASCII	0	Status of measuring system (only for application in Integral Measuring Concepts IMC, otherwise value 0) 0 = air, 1 = flushing 2 = measuring cycle, the actual gas concentrations are issued.
BX:	Analogue Input 1	ASCII	4.00	The actual transmitter output current is issued; see 4.5.
BY:	Analogue Input 2	ASCII	5.00	
BZ:	Analogue Input 3	ASCII	4.00	
CA:	Analogue Input 4	ASCII	4.00	
CB:	Analogue Input 5	ASCII	4.00	
CC:	Analogue Input 6	ASCII	4.00	
CD:	Analogue Input 7	ASCII	4.00	
CE:	Analogue Input 8	ASCII	400	

6.3.2 Series ET-4D2

Column	Content	Format	Example	Explanation
A:	Date	ASCII	08.01.2005	TT.MM.JJJJ
B:	Time	ASCII	12:23:00	HH:MM:SS
C:	Channel 1 Gas	ASCII	CH4	Denomination of measurand in clear text
D:	Channel 2 Gas	ASCII	O2	
E:	Channel 3 Gas	ASCII	---	
F:	Channel 4 Gas	ASCII	---	
G:	Channel 1 Dimension	ASCII	% (v/v)	Unit of measurand
H:	Channel 2 Dimension	ASCII	% (v/v)	
I:	Channel 3 Dimension	ASCII	% (v/v)	
J:	Channel 4 Dimension	ASCII	% (v/v)	
K:	Channel 1 Range	ASCII	100.0	Measuring range of channel with and without decimal place
L:	Channel 2 Range	ASCII	25.0	
M:	Channel 3 Range	ASCII	1000	
N:	Channel 4 Range	ASCII	1000	
O:	Channel 1 Value	ASCII	54.0	Measured value of channel with and without decimal place
P:	Channel 2 Value	ASCII	5.3	
Q:	Channel 3 Value	ASCII	0.0	
R:	Channel 4 Value	ASCII	0.0	
S:	Channel 1 ALARM 1	ASCII	1	Alarm status of channel 0 = no Alarm 1, 1 = Alarm 1
T:	Channel 2 ALARM 1	ASCII	0	
U:	Channel 3 ALARM 1	ASCII	0	
V:	Channel 4 ALARM 1	ASCII	0	
W:	Channel 1 ALARM 2	ASCII	0	Alarm status of channel 0 = no Alarm 2, 1 = Alarm 2
X:	Channel 2 ALARM 2	ASCII	0	
Y:	Channel 3 ALARM 2	ASCII	0	
Z:	Channel 4 ALARM 2	ASCII	0	
AA:	Channel 1 ALARM 3	ASCII	0	Alarm status of channel 0 = no Alarm 3, 1 = Alarm 3
AB:	Channel 2 ALARM 3	ASCII	0	
AC:	Channel 3 ALARM 3	ASCII	0	
AD:	Channel 4 ALARM 3	ASCII	0	
AE:	Channel 1 FAULT	ASCII	0	Channel fault 0 = no fault, 1 = fault
AF:	Channel 2 FAULT	ASCII	0	
AG:	Channel 3 FAULT	ASCII	0	
AH:	Channel 4 FAULT	ASCII	0	
AI:	Channel 1 MODE	ASCII	0	Operation status of channel 0 = channel deactivated, 1 = channel activated
AJ:	Channel 2 MODE	ASCII	0	
AK:	Channel 3 MODE	ASCII	0	
AL:	Channel 4 MODE	ASCII	0	
AM:	System Mode	ASCII	0	Status of measuring system (only for application in Integral Measuring Concepts, otherwise value 0) 0 = air 1 = flushing 2 = measuring cycle, the actual gas concentrations are issued

6.4 Interface Profibus DP® or ModBus®

The configuration of the control unit for operation with interface module is done factory-sides before delivery and is marked on the test certificate (in case an existing system should be converted please do not hesitate to contact the ExTox-Service.).

Please pay attention to the remarks in the corresponding amendment to this Instruction Manual.

7 Application

7.1 Measuring Function

The use of Gas Detection Systems for explosion and health protection requires special care. Besides qualified support of ExTox and the detailed information in the Instruction Manuals as well as Technical Data Sheets (TDB) there are several guides to assist you for the safe use and operation of Gas Detection Systems. These guides deal with the selection, installation, initial operation and regular maintenance.

Furthermore there could be national regulations. In Germany there are for example the guidelines of the Berufsgenossenschaften BGI 518 and BGI 836 obligatory for certain applications.

Denomination	Title
EN 60079-29-2	Explosive atmospheres – Part 29-2: Gas detectors – Selection, installation, use and maintenance of detectors for flammable gases and oxygen
Merkblatt T023, BGI 518	Gaswarneinrichtungen für den Explosionsschutz - Einsatz und Betrieb
Merkblatt T055, BGI/GUV-I 8617	Mess- und Warngeräte für den Explosionsschutz – Antworten auf häufig gestellte Fragen
EN 45544-4	Electrical devices used for the direct detection and direct concentration measurement of toxic gases and vapours - Part 4: Guide for selection, installation, use and maintenance
Merkblatt T021, BGI 836	Gaswarneinrichtungen für toxische Gase/Dämpfe und Sauerstoff - Einsatz und Betrieb
EN 50292	Electrical apparatus on the detection of carbon monoxide in domestic premises – Guide for the selection, installation, use and maintenance
EN 50244	Electrical apparatus on the detection of combustible gases in domestic premises – Guide for the selection, installation, use and maintenance

DIN-Standards available at VDE-Verlag, Frankfurt or Beuth-Verlag, Berlin
BGI available at Jedermann-Verlag, Heidelberg

7.2 Use in combination with hazardous Areas

The Control Unit itself may not be installed in hazardous areas, but it is allowed to use the control unit in combination with explosion protected transmitters. Please note the corresponding installation hints for each individual transmitter.

All types of control units can be used in combination with hazardous areas of Zone 2.

For use in combination with Zone 1 ExTox offers types with EC-Type Test BAM 10 ATEX 0301 X. These types are always supplied with Software Version ET881118 (ET-8D) or ET481118 (ET-4D2) and show the special marking $\text{CE} \text{ II (2)G}$ on the type label.

Deviations of the EC-Type Test-Software Version in comparison to the current Software Versions are described in grey writing within this Instruction Manual.

Please pay attention to the remarks regarding configuration of the control unit and its function in the safety system when using the detection system in combination with hazardous areas.

8 Installation

8.1 Mechanical Installation

The control unit should be installed at an easily accessible place to enable the reading out of messages at every time and to ensure an easy maintenance.

Please note the indicated operation temperature (☞DB). The control unit should be installed protected against weather conditions, such as for example driving rain, and bigger climatic fluctuations. If necessary a suitable protection has to be provided.

The dimensions for assembly and further installation dimensions to be taken from the Technical Data Sheet (☞DB).

The type in wall mounted housing and for installation in control panels or 19"-Rack are fix screwed up. The type for DIN-Rail installation disposes of four fixtures with which the housing is snapped on the DIN-Rail. By pulling the handles standing out of the backside of the device the connection can easily be untied and the device can be taken off.

The control units may not be installed in hazardous areas.

8.2 Electrical Installation

The electrical installation may only be done by electro specialists according to the installation regulations on the subject. There are especially regulations for the Installation of Information Engineering IEC 60364 (in Germany VDE 0800) and for lightning protection according to EN 62305 (in Germany DIN V VDE V 0185). The power supply of the control unit has to meet the requirements of an arrester of Class C or of Type 2. Please note that there might be special requirements in case control unit and transmitters are installed in separated rooms.

The control units are designed for industrial application. *Warning:* The control units are Class A devices. It may cause radio interferences in living quarters. In this case the user may demand performances of suitable measures.

When running the cable you should pay attention to the fact that the cables for the gas sensors should better be run separately and protected against mechanical damages.

On the type in wall mounted housing and for DIN-Rail installation the housing has to be opened. To do this you have to remove the blind plates on the left and right side of the front and unscrew the four screws. The cover can now be opened and tucked up. The connections are in the bottom part of the housing. The big cable gland M20x1.5 serves for the power supply cable.

On the types for installation in control panel or 19"-Rack the PCB including clamps is mounted in a separate part of the housing, which has to be installed at the adequate place in the enclosure. Both components are electrically linked by means of three included ribbon cables. In case the standard length (☞DB) does not fit, please do not hesitate to contact ExTox. As an option the different types can also be supplied in combined "Sandwich"-design. In this case the clamps are freely accessible on the backside of the housing.

The control unit starts operation automatically with connection to the power supply.

You could find the connection scheme for input and output in the Technical Data Sheets (☞DB) and also marked on the PCB. Connection is done via plug clamps. Remove the plug before connecting the cable to avoid mechanical damage. After the assembly is done you could connect the plug again.

The connection PCB shows a spatial separation of the transmitter inputs and the relay outputs. The overlapping of lines between these two areas within the housing and on the PCB should be avoided. It should especially be ensured that correct isolation is kept in case cables of different voltage get in contact. We recommend not removing the protection isolation directly after the cable gland but only close to the corresponding clamp.

ET-8D: grounding can be done via the clamp block SLD of the transmitter inputs.

ET-4D2: normally the shield of the transmitter cable should not be passed into the control unit ET-4D2. PE-lines can be connected to the clamp SHLD of the corresponding channel. In

this case the connection between the pins SHLD and PE has to be set at the Jumper J 4001 (between Relay K9 and input channel CH1).

Please bear in mind that the cable glands have to be firmly tightened to ensure the sufficient strain-relief. Not used cable glands have to remain closed with already installed plugs.

8.3 Smoke Detectors

Please pay attention to the differences between the control unit types ET-8D and ET-4D2.

8.3.1 Series ET-8D

Optical smoke detectors DP721R (Art.-No. 297000) can be connected to the ET-8D. But each measuring channel can only run up to 4 smoke detectors in line. The smoke detector(s) is / are connected according to below wiring scheme.

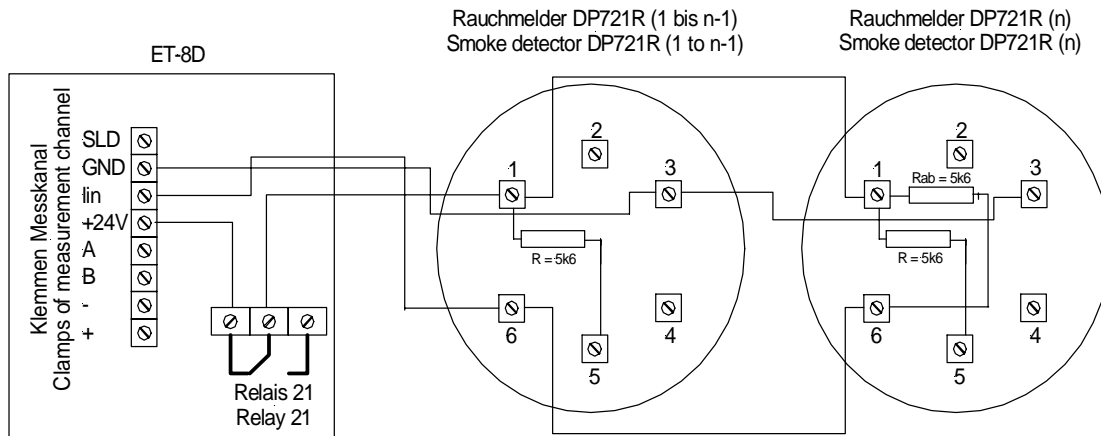

Inside the ET-8D Relay K21 has to be included into wiring. For several smoke detector lines the supplies (clamp 1) should all be done from the mid contact ("Common") of Relay K21. In all smoke detectors resistors ($R = 5.6 \text{ k}\Omega$) have to be installed between clamps 1 and 5. For the last smoke detector of each line and additional terminating resistor ($R_{ab} = 5.6 \text{ k}\Omega$) has to be installed additionally between clamps 1 and 6.

The resistors are included in the red protection caps or already installed.

8.3.2 Series ET-4D2

Optical smoke detectors DP721R (Art.-No. 297000) can be connected to the ET-4D2. To do this the corresponding measuring channel has to be configured accordingly. This configuration is done factory-sided before delivery. The connection clamps for measuring channels which are especially prepared for smoke detectors are marked accordingly. Alignment is done according to below scheme. Each measuring channel can only run up to 4 smoke detectors in line.

Attention: in case an existing system should be converted please do not hesitate to contact the ExTox-Service.

ET-4D2 (up to December 2013)

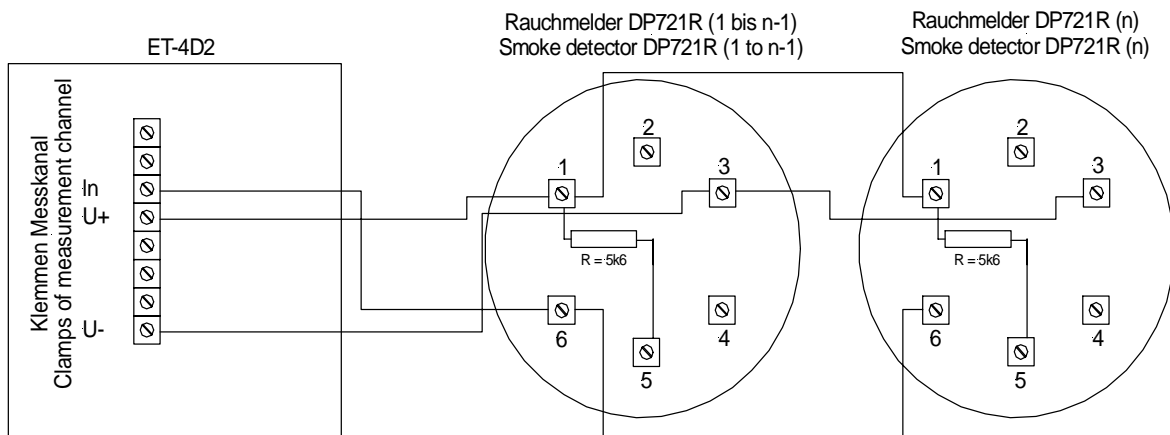

ET-4D2 since software REV131209R (January 2014)

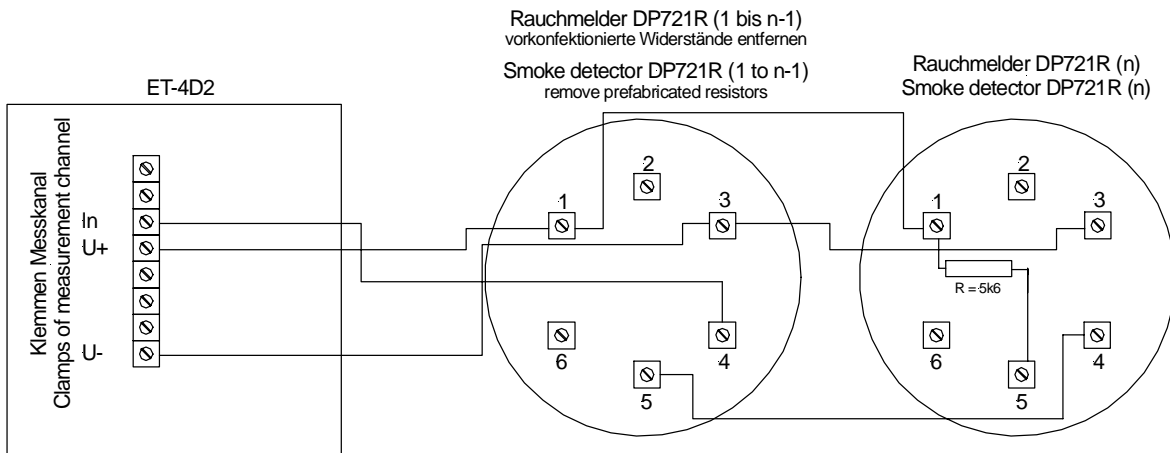

In all smoke detectors resistors ($R = 5.6 \text{ k}\Omega$) have to be installed according to the figures. The resistors are included in the red protection caps or already installed.

9 Maintenance of Gas Detection Systems

The following descriptions are generally valid for Gas Detection Systems of the company ExTox GmbH consisting of the herein described control units and connected transmitters.

9.1 Basic Information

Maintenance done by specialists is an indispensable measure for checking and keeping the functionality of gas detection systems. Maintenance comprises inspection, calibration and adjustment as well as functional test of the complete system.

Most important is the testing of the connected transmitters. Control of the gas detection system and its correct functionality are also checked.

ExTox recommends for all of her supplied transmitters regular calibration and adjustment with test gas during functional and system checks. Please see also the details in the corresponding Technical Data Sheets (☞DB). An extension to 12 months might eventually be possible in case of existing experiences on similar applications. The functionality of the Control Unit has to be tested as well.

Furthermore national valid regulations to define maintenance intervals may exist. In Germany it is for example necessary in certain applications to keep Betriebssicherheitsverordnung (BetrSichV) and the information of the professional associations T 023 und T 021 (vgl. 7.1). ExTox recommends generally speaking the application of the measures described in the information of the professional associations as well as the maximum calibration intervals even if the application does not fit into their scope.

Explosion Protection (T 023)	Maximum Intervals	
	Toxic Gases/Vapours and Oxygen (T 021)	
1 Month (Visual Check)	1 Month (Visual Check)	
4 Months (Functional Check)	6 Months (Functional Check)	
1 Year (System Check)	1 Year (System Check)	

You as user of the gas detection system bear the responsibility for the correct performance of the maintenance. ExTox as manufacturer can only place all necessary details to build up your specific maintenance concept at your disposal. We are glad to support you with this task and to submit a maintenance quotation acc. to your special requirements.

The results of each maintenance should be documented even if it is not specifically required. Hereafter the main contents of the intended checks are described. You will find details in the above mentioned bulletins.

9.2 Visual Check

You have to check your system on mechanical damages, dust, dirt, state of a sampling system if included. Furthermore indications and status messages have to be checked.

9.3 Functional Check

The functional check also comprises calibration by means of application of test gases and a suitable system for application of test gas. When calibrating the indication of measured values at application of test gas is determined and compared with the nominal values. In case the settings are corrected additionally the process is called adjustment. In case of combination with sampling systems their correct function has also to be checked. It is not necessary to trigger the switching functions.

A functional check should only be done, if there is no alarm present. You should ensure the same environmental conditions during this process as valid for the measuring process. For example a transmitter used in cold storage houses should not be adjusted under normal ambient temperatures, as there might be more or less remarkable deviations depending on sensor type.

Make sure that measures have been taken to avoid unintended triggering and transmission of alarms before applying test gas. Activate the alarm bypass in service mode at your ExTox Control Unit, deactivate automatically triggering protection measures or inform the responsible maintenance personnel. The measures corresponding to your application have to be determined and the person in charge for maintenance has to be familiar with all details.

9.4 System Check

The system check additionally comprises the triggering of switching functions; check of system parameters and of indication and recording facilities.

10 Options

Article-Number	Description
297000	Optical Smoke Detector DP721R
930052	Frame Rack for 19"-Rack 6HE, 84 TE
825000	Un-interruptible Power Supply incl. Housing
825003	Un-interruptible Power Supply for Installation in Enclosure
825006	Data Logger ET-SL
825009	ProfiBus-Interface Module
825017	Modbus-Interface Module
825022	ProfiNet-Interface Module
840012	ET-View / ET-Diag: Visualisation Software for up to 16 Control Units
840020	Special Software Monitoring Working Place Concentrations (only ET-8D)

11 Technical Data and Declaration of Conformity

The Data Sheet of the control unit contains all technical data (☞DB).

Data sheets and Declaration of Conformity are added to the documentation separately.